

HCS 1.5. The countersinkable compression screw.

Instructions for Use

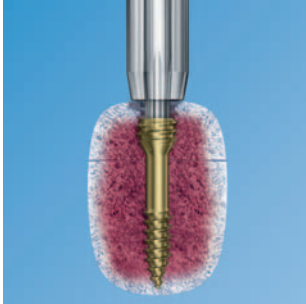
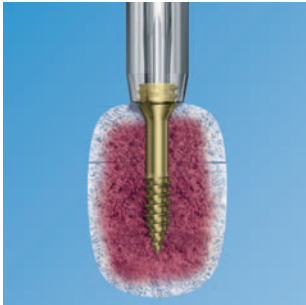
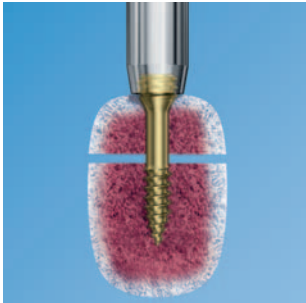

Table of Contents

Introduction	HCS 1.5	2
	Indications	4

Surgical Technique	Surgical Technique for HCS 1.5	5
	Screw Extraction	11

Product Information	Implants HCS 1.5	12
	Instruments HCS 1.5	13
	Sets	15
	Overview of Product Line HCS	16

 Image intensifier control

Warning

This description alone does not provide sufficient background for direct use of the product. Instruction by a surgeon experienced in handling this product is highly recommended.

Reprocessing, Care and Maintenance of Synthes Instruments

For general guidelines, function control and dismantling of multi-part instruments, please refer to: www.synthes.com/reprocessing

HCS 1.5. The countersinkable compression screw.

Stardrive T4

For optimal torque transmission



Ø 2.2 mm head thread

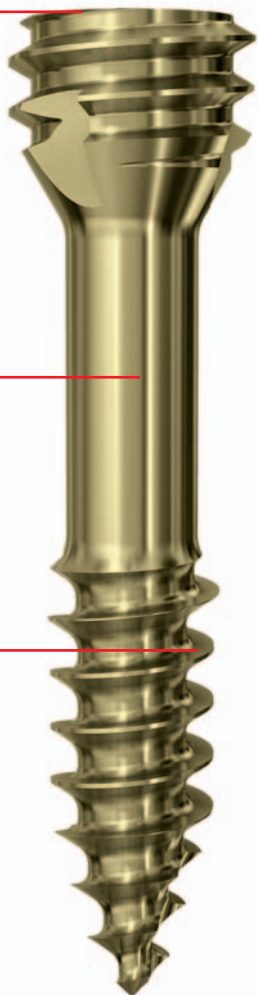

Ø 1.2 mm core diameter

Ø 1.5 mm shaft thread



Cutting flutes on screw head

Facilitate countersinking of the screw.

Identical pitch of head and shaft threads

For controlled closure and compression of the fracture gap.

Available in steel and titanium

All Headless Compression screws from Synthes are available both in stainless implant-grade steel and high-quality biocompatible titanium alloy (TAN).

Self-drilling tip

Shorter surgery due to simplified surgical technique.

Functional principle: lag screw technique with compression sleeve

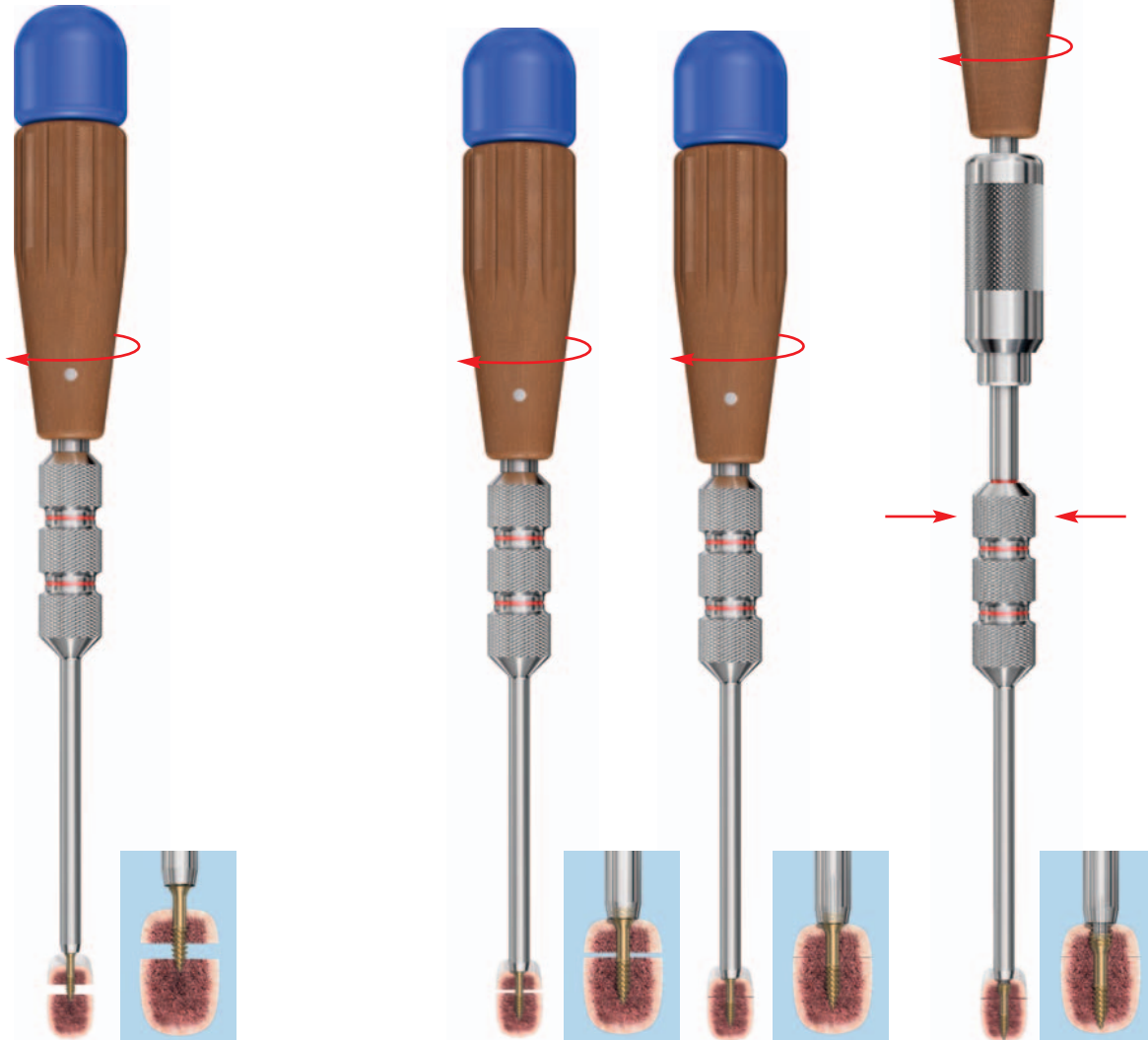

Step 1: Screw insertion

Insert the screw into the bone with the compression sleeve.

Step 2: Closure of gap and compression

Once the tip of the compression sleeve lies on the bone, the fracture gap is closed and compressed by turning the sleeve.

Step 3: Countersinking

Once the desired degree of compression is achieved, the screw is countersunk into the bone with the screwdriver while the compression sleeve is held stationary. During countersinking, no additional compression is generated.

Indications

-
- Fixation of intra- and extra-articular fractures and non-unions of small bones and small bone fragments
 - Arthrodesis of small joints
 - Osteochondral fractures
 - Osteotomies
 - Avulsion fractures

Surgical Technique for HCS 1.5

1a

Predrilling for screw

Instruments

310.110	Drill Bit \varnothing 1.1 mm, length 60/35 mm, 2-flute, for Quick Coupling
312.140	Double Drill Guide 1.5/1.1

After a stab incision, advance the drill guide through the soft tissues to the bone. Insert the drill bit through the drill guide to the bone and drill to the desired depth.

- Verify drill depth using the image intensifier.

Notes

- The HCS 1.5 is self-drilling and may be inserted without predrilling.
- Omitting the predrill step does not allow for accurate length measurement and it may be more difficult to insert the screw in hard cortical bone.

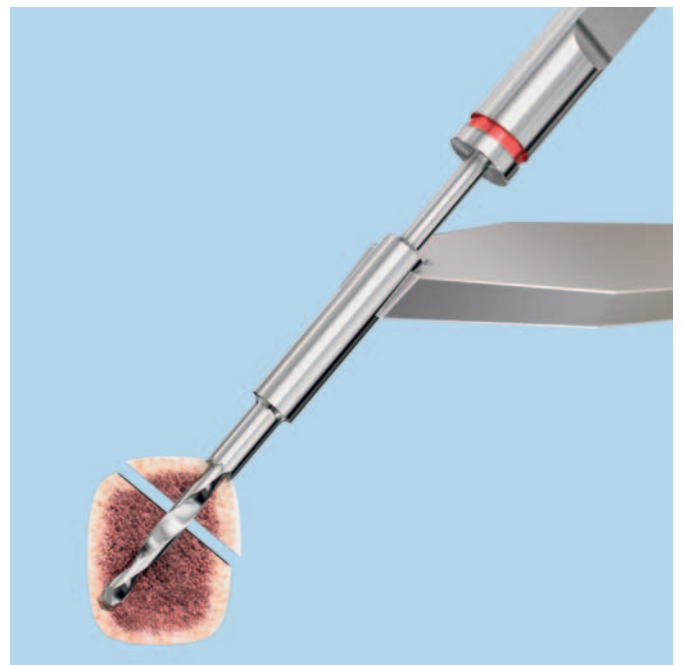

1b

Predrilling for head

Instruments

310.509	Drill Bit \varnothing 1.8 mm, length 110/85 mm, 2-flute, for Quick Coupling
323.202	Universal Drill Guide 2.4

It is recommended to predrill the near cortex with the drill bit to facilitate head insertion in dense bone and to prevent the bone from cracking.

Insert the drill bit in the drill guide and carefully predrill the cortex.

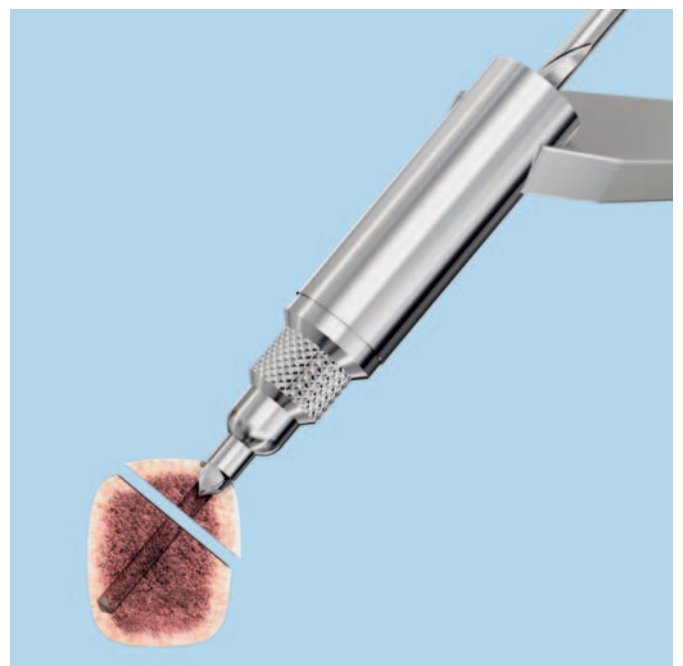

2

Determine screw length

Instrument

319.003	Depth Gauge for Screws 1.3 to 1.5 mm, measuring range up to 24 mm
---------	--

Measure the screw length using the depth gauge.

Important

Consider the following when selecting the screw length:

- Account for fracture gap compression
 - Account for desired countersinking depth
 - Ensure the self-drilling screw tip will not penetrate the far cortex
-

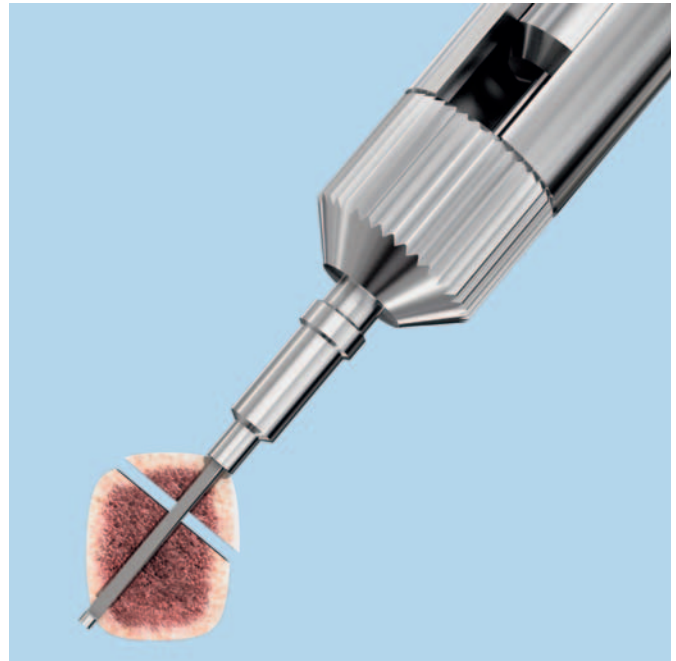

3

Pick up screw

Instruments

03.230.003	Compression Sleeve for HCS – Headless Compression Screw Ø 1.5 mm
319.970	Screw Forceps, self-holding, length 85 mm

To remove a screw from the screw rack, twist the compression sleeve over the head thread of the screw or use the screw forceps.

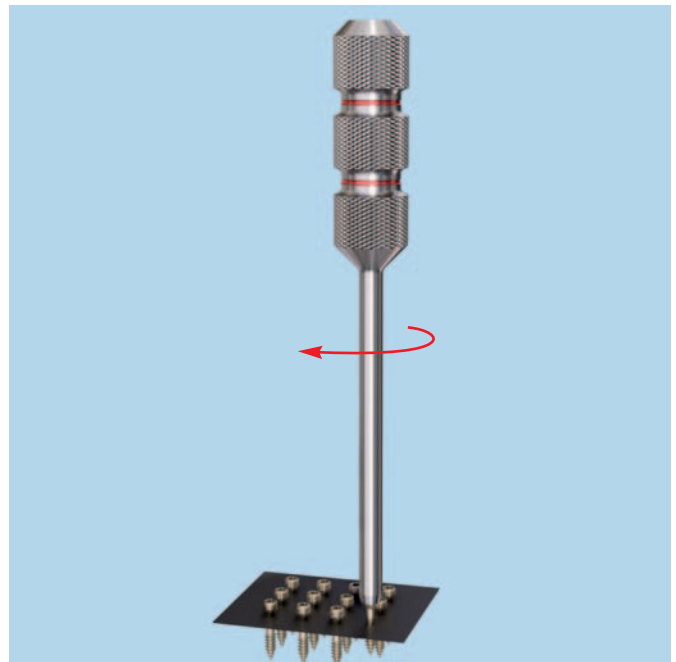

The position of the fracture line determines the screw length:

Correct screw length

The shaft thread lies below the fracture gap and completely within the distal fragment during compression. Fragments can be compressed.

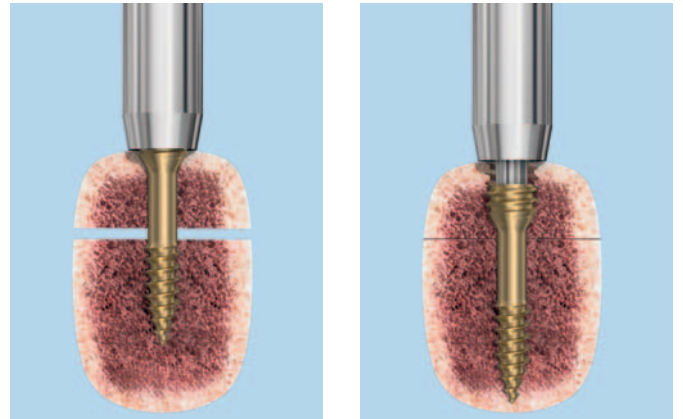

Incorrect screw length

The shaft thread bridges the fracture gap or the osteotomy. Fragments cannot be compressed.

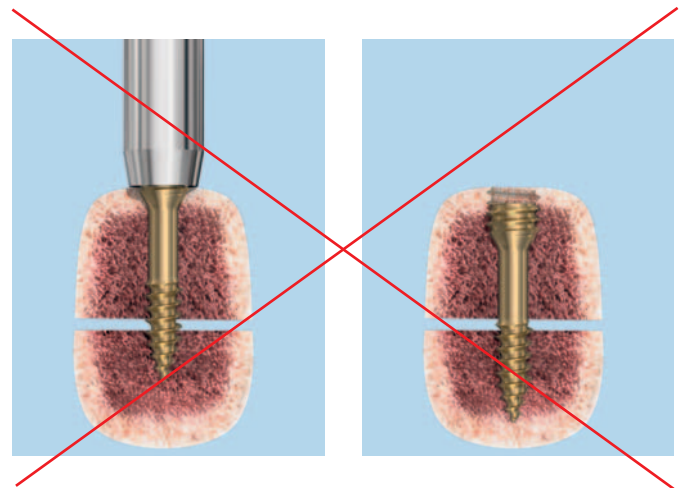

4**Insert screw and compress fragment****Instruments**

03.226.006	Handle for Compression Sleeve
03.230.003	Compression Sleeve for HCS – Headless Compression Screw \varnothing 1.5 mm

Slide the handle into the compression sleeve. Insert the screw into the bone by turning the compression sleeve until the fracture gap or the osteotomy is closed and compressed.

Note: Verify the correct position of the shaft thread in the distal fragment using the image intensifier. If the thread bridges the fracture gap or the osteotomy, the gap cannot be compressed.

Carefully tighten the screw with the compression sleeve. Forceful tightening could cause stripping of the shaft thread.

If the thread strips, some or all of the compression will be lost. If the screw is then countersunk correctly, the thread will regain purchase, thereby reducing the danger of postoperative screw loosening.

If loss of compression makes screw extraction necessary, follow the instructions on screw extraction on page 11.



5

Countersink screw

Instruments

03.230.004 Screwdriver Shaft, Stardrive, T4, with colour marking, for HCS – Headless Compression Screw \varnothing 1.5 mm

311.430 Handle with Quick Coupling, length 110 mm

03.230.003 Compression Sleeve for HCS – Headless Compression Screw \varnothing 1.5 mm

Remove the handle for compression sleeve from the compression sleeve. Assemble the screwdriver shaft to the handle with quick coupling and slide it through the compression sleeve into the recess of the screw.

Countersink the screw by turning the screwdriver shaft while simultaneously holding the compression sleeve stationary.

Important: Verify the screw position with the image intensifier. Ensure that the screw tip does not penetrate the far cortex and that the screw head is properly countersunk.

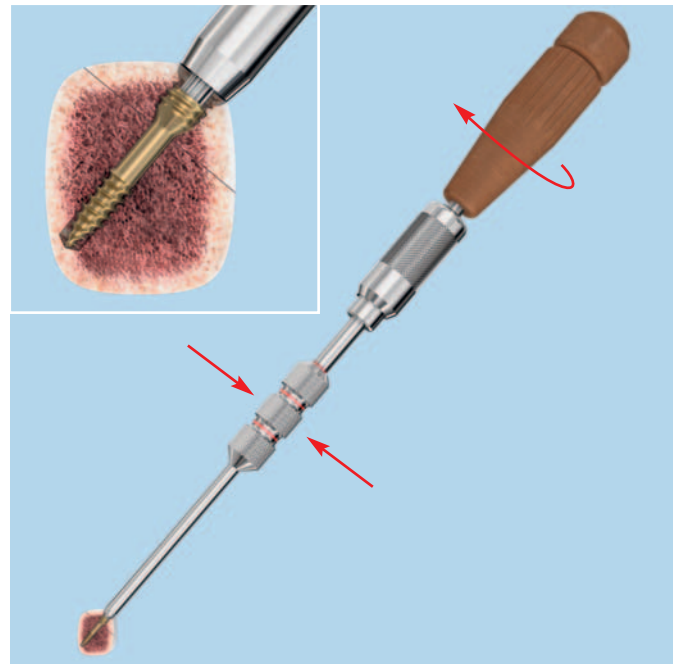
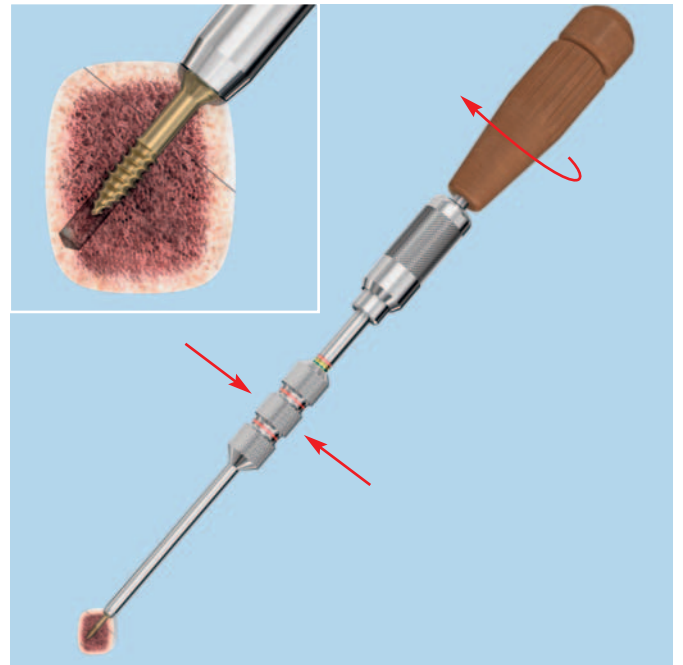

Color markings

The color markings on the screwdriver shaft indicate the position of the screwdriver tip and the head thread of the screw in the bone.

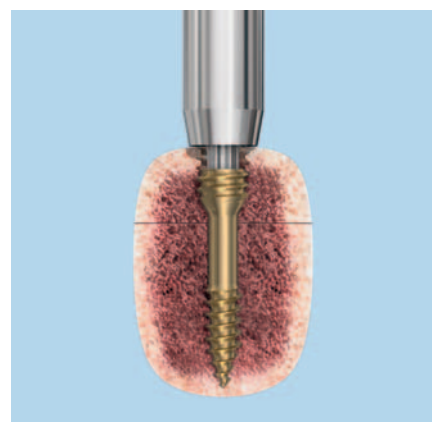
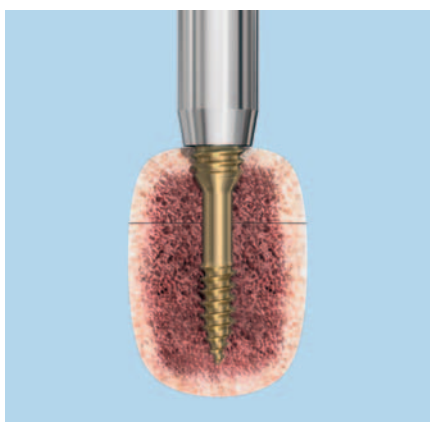
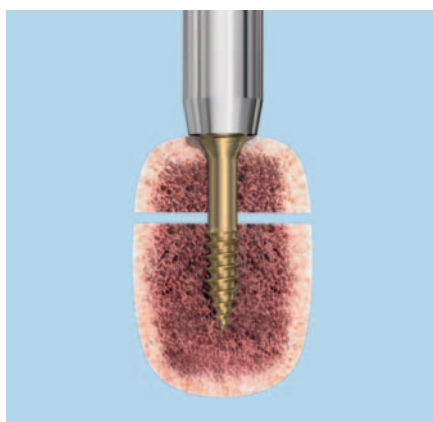
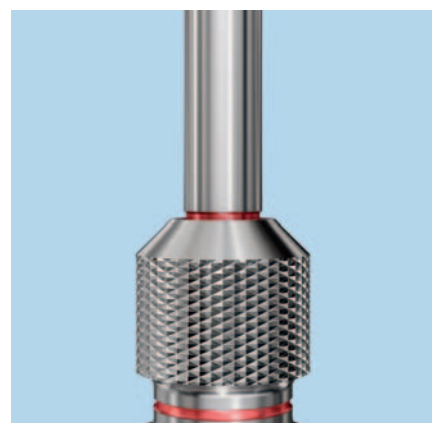
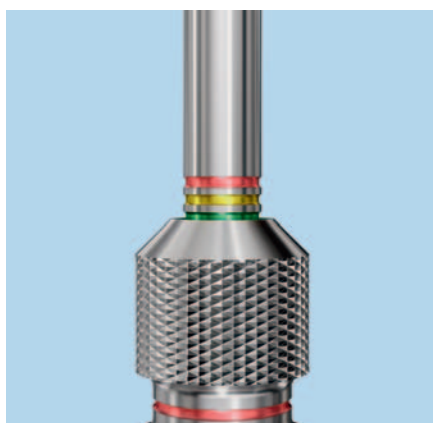

Green mark flush with the top end of the compression sleeve

The screw is fully threaded into the compression sleeve and the screwdriver tip is seated correctly in the recess of the screw.

Yellow mark flush with the top end of the compression sleeve

The top end of the head thread is even with the bone surface.

Red mark flush with the top end of the compression sleeve

The top end of the head thread is approximately 1 mm below the bone surface.

Note: If the screw is inserted at an angle, it must be countersunk further than the yellow mark so that it does not project from the surface.

Screw Extraction

Instruments

03.230.004	Screwdriver Shaft, Stardrive, T4, with colour marking, for HCS – Headless Compression Screw \varnothing 1.5 mm
311.430	Handle with quick coupling, length 110 mm
03.230.003	Compression Sleeve for HCS – Headless Compression Screw \varnothing 1.5 mm
309.200	Hollow Reamer, complete, anticlockwise cutting, for Screws \varnothing 2.0 mm

For the extraction of the HCS 1.5 use the Screwdriver Shaft in combination with the handle with quick coupling.

If the screw strips, use the following procedure:

Thread the compression sleeve over the screw head thread. Insert the screwdriver through the compression sleeve into the recess of the screw.

Remove the screw by simultaneously pulling on the compression sleeve and turning both the screwdriver and the compression sleeve in counterclockwise direction.

Note: If necessary, expose the recess and part of the head thread with a hollow reamer (e.g. 309.200) or use another preferred method.

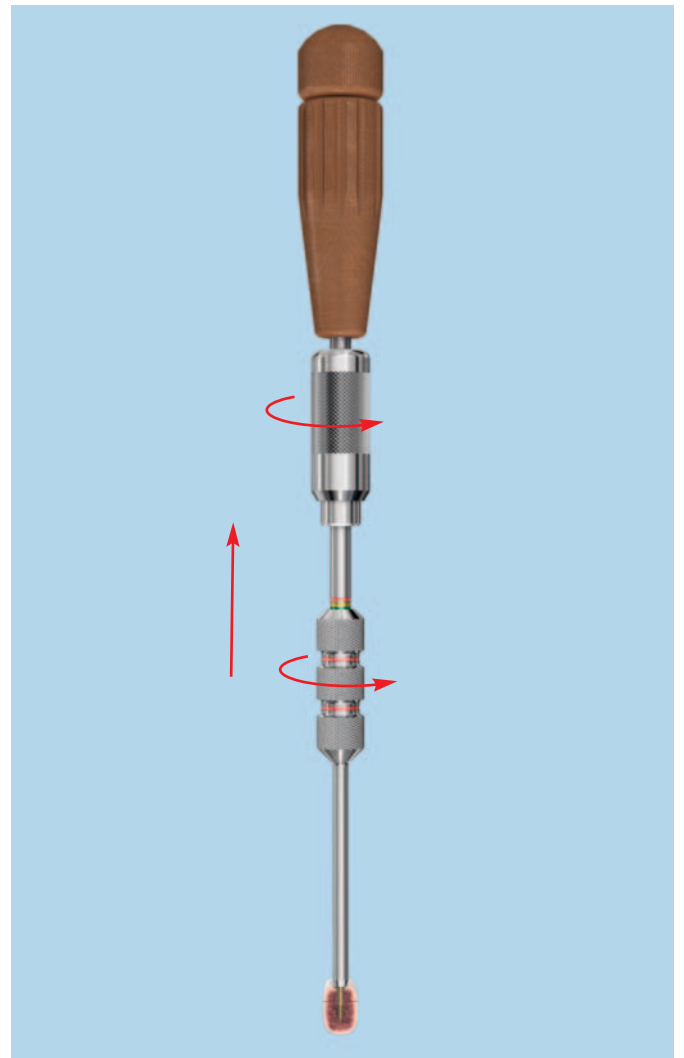

Implants HCS 1.5

HCS 1.5 – Headless Compression Screw, self-drilling

Art. No.	Screw length (mm) L	Shaft thread length (mm) S
0X.230.108	8	4
0X.230.109	9	4
0X.230.110	10	4
0X.230.111	11	4
0X.230.112	12	4
0X.230.113	13	4
0X.230.114	14	4
0X.230.115	15	4
0X.230.116	16	5
0X.230.117	17	5
0X.230.118	18	5
0X.230.119	19	5
0X.230.120	20	6

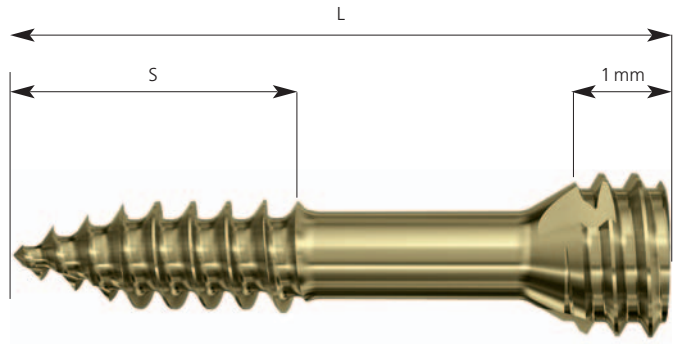

X = 2: Stainless Steel

X = 4: Titanium Alloy (TAN)

All implants are also available sterile packed. Add suffix "S" to article number.

Instruments HCS 1.5

03.230.003 Compression Sleeve for HCS – Headless
Compression Screw \varnothing 1.5 mm



03.230.004 Screwdriver Shaft, Stardrive, T4,
with colour marking, for HCS – Headless
Compression Screw \varnothing 1.5 mm



03.226.006 Handle for Compression Sleeve, for
HCS – Headless Compression Screw



311.430 Handle with Quick Coupling,
length 110 mm



319.970 Screw Forceps, self-holding, length 85 mm



312.140 Double Drill Guide 1.5/1.1



323.202 Universal Drill Guide 2.4



310.110 Drill Bit \varnothing 1.1 mm, length 60/35 mm,
2-flute, for Quick Coupling



319.003 Depth Gauge for Screws \varnothing 1.3 to 1.5 mm,
measuring range up to 24 mm



310.509 Drill Bit \varnothing 1.8 mm, with marking, length
1110/85 mm, 2-flute, for Quick Coupling



Sets

01.230.002 Instrument and Implant Set for HCS –
Headless Compression Screw Ø 1.5 mm
(Stainless Steel) for Vario Case

01.230.004 Instrument and Implant Set for HCS –
Headless Compression Screw Ø 1.5 mm
(Titanium Alloy) for Vario Case

Overview of Product Line HCS

Thread \varnothing	Material	Thread length	Screw length	Guide wire \varnothing
1.5 mm	Stainless Steel/TAN	Variable (4–6 mm)	8–20 mm	Not cannulated
2.4 mm	Stainless Steel/TAN	Short thread (variable)	9–20 mm	1.1 mm
2.4 mm	Stainless Steel/TAN	Long thread (variable)	16–40 mm	1.1 mm
3.0 mm	Stainless Steel/TAN	Short thread (variable)	10–40 mm	1.1 mm
3.0 mm	Stainless Steel/TAN	Long thread (variable)	16–40 mm	1.1 mm
4.5 mm	Stainless Steel/TAN	Short thread (variable)	20–110 mm	2.8 mm
4.5 mm	Stainless Steel/TAN	Long thread (variable)	30–110 mm	2.8 mm
6.5 mm	Stainless Steel/TAN	Short thread (variable)	30–150 mm	2.8 mm
6.5 mm	Stainless Steel/TAN	Long thread (variable)	45–150 mm	2.8 mm



Synthes GmbH
Eimattstrasse 3
CH-4436 Oberdorf
www.synthes.com

All technique guides are available as PDF files at
www.synthes.com/lit



CE
0123